

通用规格 (General specifications)

步距精度.....5%
 温升.....80 Max
 环境温度.....-20 ~+50
 绝缘电阻.....100M Min 500VDC
 耐压.....500V AC 1minute
 径向跳动.....最大 0.06mm (450g 负载)
 轴向跳动.....最大 0.08mm (450g 负载)



电气规格 (Specifications)

型号	步距角	电机长度	保持转矩	额定电流	相电阻	相电感	转子惯量	电机重量
Model	Step Angle (°)	Length L(mm)	Holding Torque (N.m)	Current (A/Phase)	Resistance (Ω)	Inductance (mH)	Rotor inertia (g.cm ²)	Weight (Kg)
BS110HB99-05	1.8	99	10	5	0.72	9.8	5500	5
BS110HB115-06		115	12	6	0.44	4.9	7200	6
BS110HB150-06		150	20	6	0.8	9.4	10900	8.4
BS110HB201-08		201	27	8	0.6	11	16200	11

外形尺寸 (Dimension)

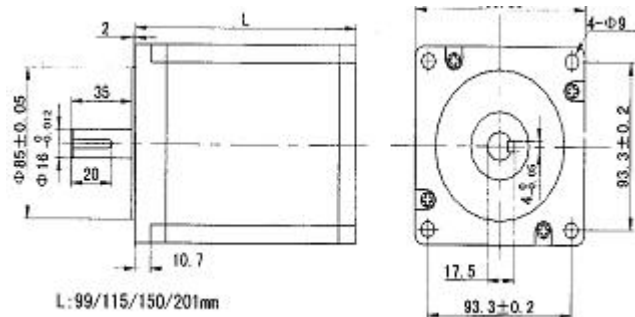

型号	轴径	轴伸(mm)
BS110HB99-05	16mm	平键 6×25
BS110HB115-06	16mm	平键 6×25
BS110HB150-06	16mm	平键 6×25
BS110HB201-08	16mm	平键 6×25

矩频特性曲线图 (Frequency-torque characteristics)

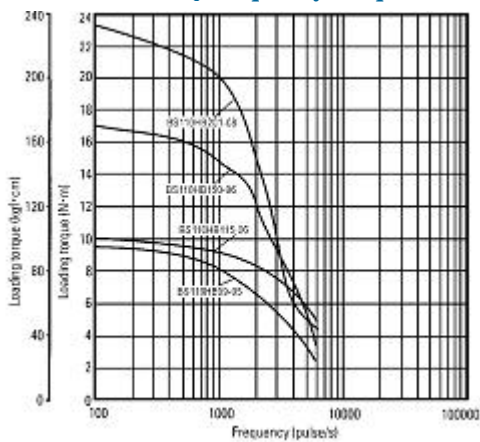

接线图 (Connections)

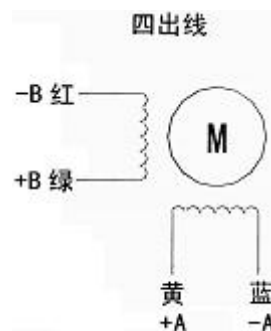

测试条件 (Testing Conditions)

驱动器型号：Q2HB110M

测试电压：110V DC